

Direct Reduction of Acetylene at Molybdenum Modified Polymeric Sulfur Nitride, (SN)_x, Electrodes

Judith F. Rubinson, Thomas D. Behymer, and Harry B. Mark, Jr.*

Contribution from the Department of Chemistry, University of Cincinnati, Cincinnati, Ohio 45221. Received July 1, 1981

Abstract: Electrodes assembled from crystals and films of the polymeric conductor, polymeric sulfur nitride, have been modified by being dipped in aqueous solutions of sodium molybdate or Mo₂O₂S₂²⁺ "core". These electrodes have been used at voltages of -1.46 V vs. SCE and pHs from 5.4 to 14 to produce ethylene from acetylene with little or no production of hydrogen, ethane, or 1,3-butadiene. The mechanism of reduction is significantly different from that evidenced by other Mo-S reduction systems, as shown by higher electrode activity with increasing pH and the low rate of production of the above byproducts. The effects of pH, electrode potential, and the presence of iron or cysteine are also investigated.

There has been a great deal of interest in recent years in the chemical modification of conductor surfaces in order to produce electrodes with specific analytic, synthetic, or catalytic properties.¹ The attachment of metal ion redox centers to the electrode surface has been accomplished either by direct adsorption or by using Lewis base functional adsorbed polymer groups or immobilized organic ligands.² The "inorganic metal", polymeric sulfur nitride (SN)_x, has been shown to bind metal ions directly at its surface.³ Described here is the immobilization of molybdenum on the surface of (SN)_x and the use of such molybdenum-modified electrodes in the direct electroreduction of acetylene to ethylene.

The reduction of acetylene by molybdenum compounds is of considerable interest, as these reactions could be models which could lead to an unraveling of the still poorly understood mechanism of action of the enzyme nitrogenase. This enzyme is responsible for the conversion of atmospheric nitrogen to ammonia in certain organisms. Also, it has been shown that acetylene competes with nitrogen for the active site of nitrogenase and is readily reduced.^{4,5} As the reaction of acetylene has a faster turnover time and its reduction products are easily separated by gas chromatography, it is often used as a preliminary test probe for nitrogen-reducing activity of possible nitrogenase models.

The enzyme itself consists of two protein subunits, one of which contains a Fe₄S₄ core.⁶ The structure of the second subunit,

commonly referred to as the Mo-Fe protein, is less well understood. However, extended X-ray absorption fine structure (EXAFS) experiments indicate that the molybdenum resides in a primarily sulfur environment (at least two sulfur atoms in the first coordination sphere) with several iron atoms at about 2.7 Å from the Mo center.⁷ Molybdenum complexes with coordinated sulfur atoms have, therefore, been the basis of many model studies.

Over the past 10 years, Schrauzer and co-workers have published a series of papers dealing with the reduction of acetylene, nitrogen, and other species, which are substrates of nitrogenase, by molybdenum complexes.⁸ The systems used were primarily cyano or thiol complexes of Mo(III), Mo(IV), Mo(V), or Mo(VI). Also, they were generally used in conjunction with a homogeneous reducing agent such as Fe₄S₄(SR)₄⁴⁻, BH₄⁻, and S₂O₄²⁻. The media employed ranged from slightly acidic to very alkaline (almost 12 M NaOH) aqueous solutions. In these model systems the catalytic activity of the complexes was found to decrease gradually and the rate of production leveled off after several hours. Schrauzer et al. proposed the active molybdenum to be in the +4 oxidation state, and that it oxidized to Mo(VI) upon reaction with the substrate.⁸

In contrast, Schultz and co-workers have presented evidence that the active form is a Mo(III) species.⁹ This hypothesis was based on extensive electrochemical and spectral studies of a variety of Mo-S complexes.¹⁰ They also reported the electrocatalytic reduction of acetylene to ethylene in the presence of di-μ-oxo-bis[oxo(L-cysteinato)molybdate(V)] at a mercury electrode. The electrode acts as the source of electrons in this case rather than the homogeneous reducing agents used by Schrauzer et al.⁸ Concomitant with the reduction of acetylene, 1,3-butadiene and copious amounts of hydrogen were produced. It was not obvious in this case whether the reduction of the acetylene was by a solution phase or an electroadsorbed molybdenum species.

Other aqueous systems for acetylene reduction have been described by Stiefel,¹¹ Tanaka,¹² and Ichikawa.¹³ Stiefel's system

(1) For recent reviews, see: W. R. Heineman and P. T. Kissinger, *Anal. Chem.*, **52**, 1387 (1980); Royce W. Murray, *Acc. Chem. Res.*, **135** (1980); K. D. Snell and A. G. Keenan, *Chem. Soc. Rev.*, **8**, 135 (1979); and W. Kutner, R. J. Nowak, and H. B. Mark, Jr., *Wiad. Chem.*, **32**, 817 (1978).

(2) (a) A. Bettelheim, R. J. H. Chan, and T. Kuwana, *J. Electroanal. Chem.*, **99**, 391 (1979); (b) J. P. Collman, M. Marrocco, P. Denisovich, C. Koval, and F. C. Anson, *ibid.*, **101**, 117 (1979); (c) Y. Umezawa and T. Yamamura, *ibid.*, **95**, 113 (1978); (d) Tomoji Kawai, Katsumi Tanimura, and Tadayoshi Sakata, *Chem. Phys. Lett.*, **56**, 541 (1978); (e) W. D. Johnston, H. J. Leamy, B. A. Parkinson, A. Heller, and B. Miller, *J. Electrochem. Soc.*, **127**, 90 (1980); (f) B. Parkinson, A. Heller, and B. Miller, *ibid.*, **126**, 954 (1979); (g) Hiroyuki Uchida, Hiroshi Yoneyama, and Hideo Tamura, *ibid.*, **127**, 99 (1980); (h) H. Yoneyama, S. Mayami, and H. Tamura, *ibid.*, **125**, 68 (1978); (i) J. A. Cox and A. F. Brajter, *Anal. Chem.*, **51**, 2230 (1979); (j) A. P. Brown, C. Koval, and F. C. Anson, *J. Electrochem. Soc.*, **72**, 379 (1976); (k) D. G. Davis and R. W. Murray, *Anal. Chem.*, **49**, 194 (1977); (l) K. Pool and R. P. Buck, *J. Electroanal. Chem.*, **95**, 241 (1979); (m) A. Merz and A. J. Bard, *J. Am. Chem. Soc.*, **100**, 3222 (1978); (n) R. F. Lane and A. T. Hubbard, *J. Phys. Chem.*, **77**, 1401 (1973).

(3) (a) H. B. Mark, Jr., R. J. Nowak, W. Kutner, J. F. Johnson, and A. G. MacDiarmid, *Bioelectrochem. Bioenerg.*, **5**, 215 (1978); (b) A. N. Voulgaropoulos, R. J. Nowak, W. Kutner, and H. B. Mark, Jr., *J. Chem. Soc. Chem. Commun.*, 244 (1978); (c) R. J. Nowak, Włodzimierz Kutner, Judith F. Rubinson, A. N. Voulgaropoulos, H. B. Mark, Jr., and A. G. MacDiarmid, *J. Electrochem. Soc.*, **127**, 1927 (1981); (d) A. N. Voulgaropoulos and H. B. Mark, Jr., *Anal. Lett.*, **13**, 959 (1980).

(4) Gunther Eichhorn, Ed., "Inorganic Biochemistry", Vol. 2, Elsevier, New York, 1975, p 764.

(5) William E. Newton and C. J. Nyman, Eds., "Proceedings of the International Symposium on Nitrogen Fixation", 1st Ed., Washington University Press, 1976; A. E. Shilov, Ed., "Treatise on Dinitrogen Fixation", Wiley, New York, 1979; J. R. Postgate, Ed., "Chemical and Biochemical Aspects of Nitrogen Fixation", Plenum, New York, 1971.

(6) R. H. Holm and J. A. Ibers, in "Iron-Sulfur Proteins", Vol. 3, W. Lovenbert, Ed., Academic Press, New York, 1976, Chapter 7.

(7) Stephen P. Cramer and Keith O. Hodgson, in "Progress in Inorganic Chemistry", Vol. 25, S. J. Lippard, Ed., Wiley, New York, 1977.

(8) (a) E. L. Moorehead, V. J. Weathers, E. A. Ufkes, P. R. Robinson and G. N. Schrauzer, *J. Am. Chem. Soc.*, **99**, 6089 (1977); (b) E. L. Moorehead, P. R. Robinson, T. M. Vickery, and G. N. Schrauzer, *ibid.*, **98**, 6555 (1976) and references therein; (c) G. N. Schrauzer and G. Schlesinger, *ibid.*, **92**, 1808 (1970).

(9) (a) F. A. Schultz, D. A. Ledwith, and L. O. Leazenbee, *Am. Symp. Ser.*, **38**, 78 (1977); (b) D. A. Ledwith and F. A. Schultz, *J. Am. Chem. Soc.*, **97**, 659 (1975).

(10) (a) V. R. Ott, S. S. Sweiter, and F. A. Schultz, *Inorg. Chem.*, **16**, 2538 (1977); (b) F. A. Schultz, in "Molybdenum Chemistry of Biological Significance", William E. Newton and Sei Otsuka, Eds., Plenum, New York, 1980.

(11) J. L. Corbin, N. Pariyardeth, and E. E. Stiefel, *J. Am. Chem. Soc.*, **98**, 7862 (1976).

(12) F. Tanaka, M. Tanaka, and T. Tanaka, *Chem. Lett. Jpn.*, 895 (1981).

utilized molybdothiol complexes of the form $Mo_2O_4(L_3)_2$, where L_3 is a substituted cysteine, in conjunction with $NaBH_4$. He also attempted reduction with a similar complex in which edta or its cysteine analogue, edcys, took the place of the tridentate ligands. Stiefel also reports the production of butadiene as a byproduct. Ishikawa used molybdenum complexes of the same type, and varied the charge carriers used in conjunction with them. Tanaka has described the electrochemical reduction of acetylene in the presence of a and/or b, pictured below. Potentials varied between -1.25 and -1.60 V vs. SCE.

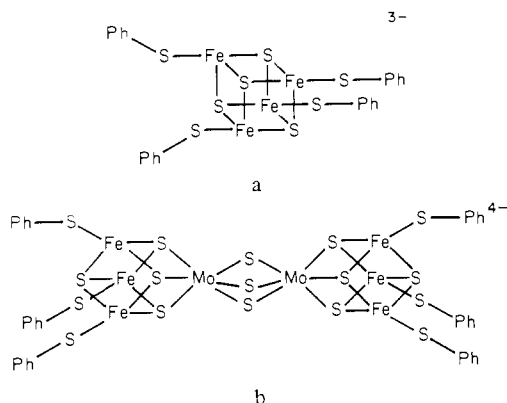

The object of our study was to definitely immobilize a molybdenum species on the surface of $(SN)_x$ in order to obtain electrocatalytic behavior similar to that reported by Schultz et al.⁹ Because of the fact that iron is also present in the enzyme nitrogenase, the effect of immobilization of iron alone, and simultaneously both iron and molybdenum, on acetylene reduction at $(SN)_x$ electrodes was also examined.

Experimental Section

Polymeric sulfur nitride was prepared by the method of MacDiarmid et al.¹⁴ with the following changes: (1) the S_4N_4 starting material was purified by sublimation no more than 1 week before use, (2) the polymerization step was allowed to continue for at least 2 weeks, and (3) the final removal of unpolymerized material was carried out for at least 12 h.¹⁴ Single-crystal electrodes were assembled and evaluated as described elsewhere.¹⁵ All except one crystal face was masked with Torr Seal. Electrodes where the chains of the $(SN)_x$ fiber bundles were perpendicular to the exposed surface (*perpendicular* electrodes) as well as those where the chains were parallel to the exposed surface (*parallel* electrodes) were employed. *Parallel* films were produced on glass microscope slide covers or Mylar by the method of MacDiarmid et al., except that the temperature of the $(SN)_x$ was raised to 150 °C over a period of about 5 h. The electrodes were assembled in the same manner¹⁵ as for crystals, with the exception that silver paste was applied along one whole edge of the film and then masked with dental sticky wax or Torr Seal.⁸ Electrodes were dipped in 1 M $Fe(NO_3)_3$ (AR grade) in 0.05 M HNO_3 , 1 M Na_2MoO_4 (AR grade), or 0.2 M $Mo_2O_2S_2^{3+}$ for 30 min unless otherwise stated. The electrodes were then rinsed with deionized water, soaked in deionized water for 30 min, and rinsed again. The 0.2 M solution of the $Mo_2O_2S_2^{2+}$ "core" was produced as described by Schultz.^{10a}

The airtight electrochemical cell used for the acetylene reduction experiments had a volume of 30 mL. It consisted of a Pyrex cup sealed with a rubber stopper through which were inserted a platinum wire auxiliary electrode, a standard calomel reference electrode, an $(SN)_x$ working electrode, and two shortened Pasteur pipets which were sealed with rubber serum caps (for gas inlet, outlet and headspace sampling by syringe). Electrochemical experiments were carried out using either a Princeton Applied Research Model 173 polarograph or a home-built potentiostat.¹⁶ The headspace samples during the acetylene experiments were obtained using a Precision Sampling Model B-110 10 μ L airtight syringe. These headspace samples were analyzed using a Varian Model

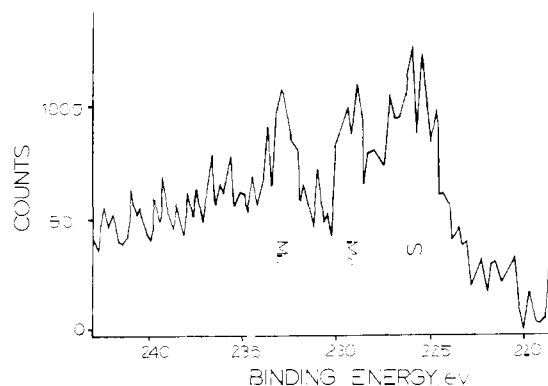

Figure 1. ESCA spectrum for the Mo(3d) binding energy region $(SN)_x$ after molybdate pretreatment.

1740 gas chromatograph equipped with a flame ionization detector (8 ft \times 0.25 in. glass column, Porapak N). Variation in peak heights for duplicate injections was less than 5%. ESCA experiments were carried out using a Kratos ES-300 photoelectron spectrophotometer utilizing Mg radiation (KE = 1256.3 eV), equipped with a Tektronix data output system. The mass spectra of headspace gases were obtained with a modified Bendix Model 12-101 Time of Flight Instrument. Sample preparations are described below.

Results and Discussion

Interaction of Mo(VI) with the $(SN)_x$ Surface. Cyclic voltammetric behavior in 0.5 M acetate (pH 4.75) or 1 M Tris (pH 8.0) buffer of electrodes dipped in aqueous MoO_4^{2-} (1 M Na_2MoO_4) or MoS_4^{2-} (saturated Na_2MoS_4) was uninformative and ambiguous with respect to molybdenum immobilization. Molybdate-dipped electrodes exhibited no new redox peaks between $+0.2$ and -1.3 V vs. SCE. In the Tris buffer, the pH is higher than neutral, so the absence of waves for molybdate reduction is not surprising if the molybdate does not form some sort of complex with the $(SN)_x$ surface. In acetate buffer, however, the pH is low enough that, if sufficient Mo(VI) was immobilized, a wave should have been present in the range studied, even if it were still in the form of Mo(VI) on the surface.^{17,18} Tetra-thiomolybdate-dipped electrodes exhibited an irreversible peak at -0.5 V vs. SCE in acetate buffer which decreased on subsequent cycling.

ESCA studies were carried out on crystals dipped in 1 M Na_2MoO_4 as described above. The sample used was a collection of about 20 crystals where both perpendicular and parallel surface were available for reaction with molybdenum. A binding energy spectrum is presented in Figure 1 for the region in which two molybdenum 3d peaks and the sulfur 2s peak appear. The low surface coverage (less than 0.05 metal atoms per sulfur) suggests that very specific sites are required for metal ion binding.¹⁹ If the dipping procedure is carried out first in the $Fe(NO_3)_3$ solution and then in Na_2MoO_4 solution, the immobilization of molybdenum seems to be enhanced, while the iron/sulfur ratio is about the same as for a sample dipped only in the $Fe(NO_3)_3$ solution. These results cannot be explained solely on the basis of surface variability,^{3d} as all samples were from the same synthetic batch, and a large number of crystals were used in order to obtain an average coverage. It is possible that this enhancement results from formation of bridged species with iron, as well as direct linkages to the surface.

Electrochemical Reduction of Acetylene. a. Necessary Conditions for Reductions. It was possible to detect the production of as little as 25 nmol of ethylene by gas chromatography.²¹ Our

(13) Masuru Ichikawa and Meshitsuka Shunsuke, *J. Am. Chem. Soc.*, **95**, 3411 (1973).

(14) C. M. Mikulski, P. J. Russo, M. S. Saran, A. G. MacDiarmid, A. F. Garito, and A. J. Heeger, *J. Am. Chem. Soc.*, **97**, 6358 (1975).

(15) R. J. Nowak, H. B. Mark, Jr., A. G. MacDiarmid, and D. Weber, *J. Chem. Soc., Chem. Commun.*, **9** (1979).

(16) T. H. Ridgway, personal communication.

(17) K. Ogura, Y. Enaka, and T. Yosino, *Electrochim. Acta*, **22**, 509 (1977).

(18) N. Hull, *J. Electroanal. Chem.*, **51**, 57 (1974).

(19) Corrected ratios were based on counts corrected as follows: $C'_i = C_i / t f n$, where C'_i = corrected counts for atom i , C_i = counts (at peak maximum) for atom i , t = dwell time, f = response factor (Berthou, ref 20), and n = number of sweeps. If a penetration depth of 20 Å is assumed, monolayer coverage would be about 0.25 metal atoms per sulfur.

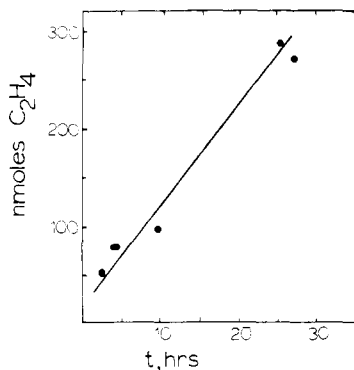

Figure 2. Ethylene production at -1.4 V vs. SCE; 50 mM Na_2MoO_4 in 0.1 M $\text{Na}_2\text{B}_4\text{O}_7$, pH 9.4; iron-dipped $(\text{SN})_x$ electrode.

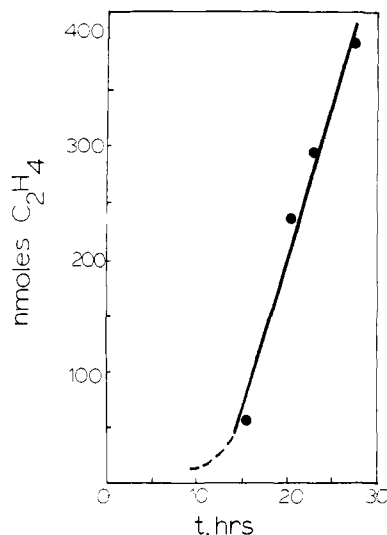

Figure 3. Ethylene production at -1.4 V vs. SCE; 50 mM Na_2MoO_4 in 0.1 M $\text{Na}_2\text{B}_4\text{O}_7$, pH 9.4; undipped $(\text{SN})_x$ electrode.

initial attempts at conversion involved an iron-dipped $(\text{SN})_x$ electrode immersed in 5 mM MoO_4^{2-} in 0.1 M $\text{Na}_2\text{B}_4\text{O}_7$ (pH 9.4), which had been saturated with acetylene. The electrode potential was set at -1.0 V vs. SCE. Gas chromatographic analysis of the cell headspace for our system showed no ethylene production after 38 h.

The molybdate concentration was then increased to 50 mM by adding Na_2MoO_4 and the voltage changed to -1.3 V vs. SCE. The same electrode and acetylene-saturated borate buffer were used as before. There was a measurable amount of ethylene produced within 24 h (63 nmol). With the same electrode and solution, and with the potential raised to -1.4 V vs. SCE, the rate increased by a factor of approximately 6. A plot of the amount of ethylene produced at -1.4 V vs. SCE vs. time is presented in Figure 2.

For determination of whether iron dipping was a prerequisite for conversion, similar electrodes not dipped in a solution of Fe(III) were immersed in the same reaction solution. The solution was saturated once again with acetylene, and the potential set to -1.4 V vs. SCE. After an initial induction period, the rate of conversion was constant for at least 30 h and about the same as obtained with prior iron-dipped electrodes. Typical results are shown in Figure 3. The iron dipping is not, therefore, necessary for acetylene reduction to take place. However, it does seem to be necessary for some process to occur between the electrode and

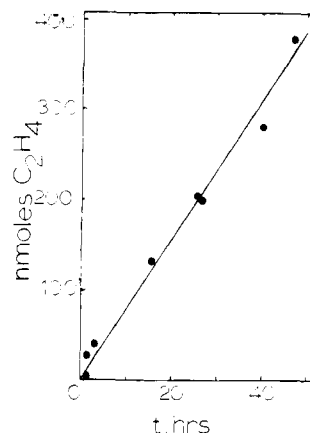

Figure 4. Ethylene production at -1.4 V vs. SCE; 0.1 M $\text{Na}_2\text{B}_4\text{O}_7$, pH 9.4; electrode dipped in 1 M Na_2MoO_4 .

Table 1. Effect of pH Variation on the Rate of Ethylene Production at Molybdate-Dipped $(\text{SN})_x$ Electrodes

pH	background electrolyte	rate/(rate at pH 9.4)
5.4	0.1 M H_3BO_3	0.38
9.4	0.1 M $\text{Na}_2\text{B}_4\text{O}_7$	1.0
13.0	0.1 M NaOH	2.8
14.0	1.0 M NaOH	4.9

the solution before the reaction can proceed, thus causing the induction period observed.

For evaluation of the possibility that some solution species other than molybdenum was the active species, fresh electrodes were placed in fresh borate solution (0.1 M $\text{Na}_2\text{B}_4\text{O}_7$, pH 9.4), the cell saturated with acetylene, and the potential set at -1.4 vs. SCE. Even after 30 h, there was no ethylene peak visible upon GC analysis of the cell headspace.

From the ESCA studies, it was found that small amounts of molybdenum could be immobilized on the $(\text{SN})_x$ surface. For determination of whether this quantity was sufficient for ethylene production, electrodes from the above blank experiments were dipped in 1 M Na_2MoO_4 according to the procedure described earlier, and the reaction was run again in borate buffer with no MoO_4^{2-} in solution. A typical plot of ethylene production vs. time for this system is shown in Figure 4. Molybdenum-dipped electrodes resulted in ethylene production at a similar rate, but it was interesting that no induction period is observed. This implies that the induction period observed above results from the slow formation of active immobilized molybdenum sites on the polarized $(\text{SN})_x$ surface from the solution species of the molybdenum.²²

Polarization of an $(\text{SN})_x$ electrode to -1.5 V vs. SCE in a 0.1 M $\text{Na}_2\text{B}_4\text{O}_7$ solution done immediately prior to dipping in 1 M Na_2MoO_4 yields an electrode having no induction period. However, the same polarization of an electrode in 1 M Na_2MoO_4 in 0.1 M $\text{Na}_2\text{B}_4\text{O}_7$ for as little as five minutes yields an electrode with 4–5 h induction period and a much slower rate than that found for the normal dipping procedure. This induction period is reasonable in light of the studies where an undipped electrode was used with Na_2MoO_4 in solution.

b. Variation of Reaction Conditions. The effects of variation of reaction conditions such as pH, applied potential, use of parallel crystal electrodes and film electrodes, and dipping in cysteine solution were also investigated. As the physical and electrochemical areas of $(\text{SN})_x$ electrodes, as well as their metal-binding capacity, vary considerably, it was necessary to test the effect of variation of a given parameter on a single electrode's activity in order to make the comparison valid within a series of experiments.

(20) Herve Berthou and Christian K. Jorgensen, *Anal. Chem.*, **47**, 482 (1975).

(21) The limits of detection were obtained by injecting ethane-ethylene-air or ethane-ethylene-acetylene mixtures in which the concentrations of ethane and ethylene were varied. Standards used during the acetylene reduction experiments involved ethylene or ethane in air.

(22) The absence of an induction period in the case of the iron-dipped electrode at -1.4 V in 50 mM molybdate is reasonable since it had been in 50 mM molybdate for 24 h before the C_2H_2 reduction plotted in Figure 2 was obtained.

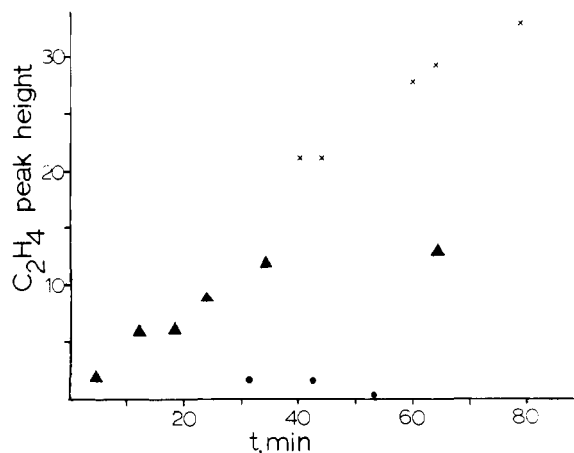

Figure 5. Loss of electrode activity for acetylene reduction upon pulsing to -1.16 V vs. SCE in 0.1 M NaOH: (x) initial production at -1.46 V, (Δ) production after 3-min pulse to -1.16 V vs. SCE, (\bullet) production after a second pulse to -1.16 V vs. SCE.

The pH range from 5.4 to 14.0 was investigated at -1.4 V vs. SCE, and the C_2H_4 production rates were compared to the rate obtained at pH 9.4. The background electrolytes at each pH, and the resulting relative rates, are given in Table I. The acceleration of the conversion rate with increasing pH was exactly the opposite of that expected from the results and the mechanism proposed by Schultz et al., in which H^+ from solution was reduced and either H_2 or a Mo-SH complex reduced the acetylene.^{9b}

At both ends of the pH range studied, there was a decrease in activity after several hours. This probably results from acid or base hydrolysis of the molybdenum from the surface as redipping restored the activity of the electrodes. An investigation of the rate of desorption at pHs from 6 to 14 was carried out as follows. A base line rate of production of C_2H_4 was established at -1.46 V and pH 13. The electrode was then immersed in a solution of a given pH which had been saturated with argon, and the potential was set to -1.46 V for 15 min. The rate was then established once again at pH 13 and -1.46 V and compared to the original rate. The new rate as a fraction of the base line rate was higher in the mid-range of pH than at pH 14, as would be expected from the results obtained above.

The effect of applied potential at fixed pH on the rate of reduction of acetylene was also investigated. At a potential of -1.59 V vs. SCE, activity was lost within about 1 h. At potentials more positive than about 1.3 V, the loss of activity was even more rapid. A base line rate of acetylene reduction was arbitrarily taken as that obtained at -1.46 V vs. SCE in a pH 13 solution for each electrode tested. After this base line rate was established, the applied potential was then stepped to -1.16 V vs. SCE and held for 3 min. The potential was then stepped back to -1.46 V and the rate of reduction redetermined. A typical set of results are shown in Figure 5. Thus, the active molybdenum sites are destroyed at potentials ± 200 mV from -1.4 V vs. SCE. This could be the result of potential-induced desorption, or potential-induced redox reactions which labilize the bound molybdenum.

As the presence of cysteine, presumably complexed to molybdenum, was necessary to effect the reduction of acetylene at the Hg electrode in the experiments of Schultz et al.,^{9b} the effect of redipping active molybdenum-dipped (SN)_x electrodes in a 1.0 M cysteine solution was determined. After the base line rate of reduction at -1.46 V in 0.1 M NaOH (saturated with C_2H_2) was established, the electrodes were dipped in the cysteine solution for several minutes, washed, and returned to the 0.1 M NaOH (saturated C_2H_2) solution and the rate of reduction measured as a function of time. Initially there was no measurable activity, but after 15–20 min C_2H_4 production commenced and the rate of production returned to its original value. Thus, the exposure to cysteine and its possible substitution at formerly labile coordination sites of the bound molybdenum poisons the electrode. This implies that the cysteine occupies coordination sites of the

molybdenum that would be involved in the C_2H_2 reduction mechanism and time is required after polarization to exchange the cysteine and give the active form of the immobilized molybdenum species.

This system differs markedly from those aqueous systems previously described in terms of the fact that virtually every publication to date dealing with nitrogenase model systems states that extensive hydrogen evolution is concomitant with the C_2H_2 reduction. This was also true of the electroreduction of C_2H_2 reported by Schultz et al.⁹ In the case of the molybdenum-dipped (SN)_x electrodes, no significant amount of hydrogen was observed when a mass spectrum of the headspace was obtained. To further investigate this, we examined the effect of molybdenum immobilization of the breakdown potential of (SN)_x electrodes. The cyclic voltammograms of undipped (SN)_x electrodes were measured in various media, the electrodes dipped in the molybdenum solution, and the cyclic voltammograms remeasured. Several interesting observations were obtained: (1) in borate media the cathodic breakdown potentials are more negative by as much as 500 mV than in acetate media at approximately the same pH values; (2) this extension of breakdown to more negative potentials in borate media was similar for both untreated and molybdenum-dipped electrodes; (3) in hydroxide media a small surface redox process is observed and the breakdown potential is extended to about -2.0 V for both untreated and molybdenum-dipped electrodes. More importantly, there is no hydrogen evolution observed even in the breakdown potential region. The breakdown currents arise from (SN)_x corrosion. Thus, it is not surprising that no concomitant H_2 evolution occurs on C_2H_2 reduction at the molybdenum-dipped electrodes as far negative as -1.5 V. The production of 1,3-butadiene has also been observed in the other systems employed.^{8,9,11} Mass spectral analysis of a headspace gas in our experiments showed less than one part in 10^3 butadiene compared to ethylene.

The electrochemical efficiency with which molybdate-dipped electrodes carry out the reduction of acetylene is variable. A molybdate-dipped electrode was held at -1.46 V vs. SCE in 0.1 M NaOH under argon until a constant current was observed (18–24 h). The electrode was then redipped, the cell purged with acetylene, and the voltage again set to -1.46 V vs. SCE. The appearance of ethylene was followed by gas chromatography and the rate of production compared to the theoretical rate based on the difference between the values at which the current leveled off under argon and under acetylene. Values of electrochemical efficiency were found ranging from 0.1 to 40%.

As treated parallel (SN)_x single-crystal electrodes reduced C_2H_2 at the same rates as perpendicular electrodes, (SN)_x film electrodes were examined in borate media. (SN)_x films consist of parallel crystallite aggregations¹⁴ and would be expected to behave as parallel electrodes made from single crystals. No C_2H_2 reduction with untreated film electrodes was observed, but C_2H_4 was produced after molybdenum dipping. Only a qualitative comparison of the production of C_2H_4 per unit electrode area for single crystals vs. film electrodes was possible as the (SN)_x films began to separate from the glass or mylar substrate over periods of hours. In general, the rates of C_2H_4 production per unit area for film electrodes fell in the lower end of the range found for single-crystal electrodes. During these experiments, distinct bubbles evolved from the working electrode. Mass spectral analysis of the headspace showed again there was no hydrogen production and C_2H_4 was the only significant product. Thus, the evolving gas is probably C_2H_4 , which is not surprising as C_2H_4 is significantly less soluble in alkaline aqueous media than in C_2H_2 .²³

c. Modification with $Mo_2O_5S_2^{2+}$ "Core". Perpendicular (SN)_x electrodes which had been dipped in a 0.2 M solution of the $Mo_2O_5S_2^{2+}$ core according to the procedure described above have been found to reduce acetylene to ethylene at rates similar to those found with molybdate-dipped electrodes after an induction period of 1–2 h. This induction period is logical in view of Schultz's hypothesis of the necessity of dimer breakdown,⁹ and our conclusion that very specific sites must be created in order for reduction to take place. This same sort of induction period was also

observed when molybdate-dipped electrodes were dipped in a solution of cysteine. This suggests that there must be coordination sites readily available for coordination of acetylene.

d. Attempted Reduction of N₂. The obvious experiment, the reduction of nitrogen to ammonia, was attempted at molybdate-dipped electrodes but it was impossible to determine if any NH₃ production from N₂ occurred. The reason is that there appears to be large amounts of NH₃ produced by electrode decomposition itself under argon atmosphere alone.²⁴ This decomposition took place at similar rates both at dipped and undipped electrodes, continuing for approximately 24 h and resulting in the apparent production of 14 mmol of NH₃. Employing a nitrogen atmosphere in the cell, the rate of ammonia production for both undipped and dipped electrodes was the same within experimental error.

Conclusion

As indicated by the ESCA data, the dipping of both parallel and perpendicular (SN)_x electrodes in Mo(VI) solution results in the immobilization of small amounts (<10% monolayer coverage) of a molybdenum species on the surface. A comparison of electrochemical and ESCA data shows that the surface concentration varies significantly from electrode to electrode. The active species once formed is very inert to exchange in the pH range of 8–10 as shown by the fact that C₂H₂ reductions can be carried on over a period of days with little loss of activity. All these results suggest that the molybdenum is bound to the surface of the (SN)_x in a multidentate fashion and that this site has some special and not common configuration and/or composition. The molecular nature of the immobilized molybdenum site at the polarized electrode cannot be inferred from these data. The oxidation state of the molybdenum also cannot be inferred, since even photoelectron spectroscopic data provide ambiguous answers due to electronic interaction between molybdenum and the atoms to which it is bound.²⁵

Exposure of a molybdenum-dipped (SN)_x electrode to cysteine solution initially destroys the catalytic activity but the fact that the activity returns after a period of time shows also that bound molybdenum is labile to ligand exchange with respect to the cysteine. It also shows that the active bound molybdenum probably has some labile coordination sites, presumably occupied with OH⁻ or water at the operating pH, which must be available to interact with acetylene during the reduction process. The increase in C₂H₂ reduction rate with increasing pH is particularly surprising and exactly the opposite to the electrochemical reductions at mercury electrodes in the presence of molybdenum-cysteine complexes⁹ and unsaturated organics in nonaqueous media containing proton donors.²⁶ This suggests that a possible mechanism would involve a rate-determining step where acetylene loses a proton in forming an end-on activated complex with the bound molybdenum:

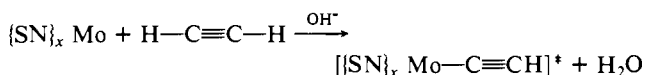

Such a mechanism is quite different from that which appears to be operative for nitrogenase⁴ and most nitrogenase models for acetylene reduction.^{8,9} An alternative mechanism could involve OH⁻ attack on the (SN)_x surface itself.

Iron-dipped (SN)_x electrodes showed little C₂H₄ production.²⁷ Molybdenum-iron-treated electrodes showed the same range of rates of C₂H₂ reduction as molybdenum dipped alone. Thus, the

Table II. Comparison of Rate of Conversion of Acetylene to Ethylene at Molybdenum-Modified (SN)_x Electrodes with that of Chemical Catalysis Systems

system used	rate (mols C ₂ H ₂ / mol Mo/min)
1 mmol thioglycerol, 2 mmol Na ₂ S ₂ O ₄ , 1 M NaOH, 1 mmol Na ₂ MoO ₄	1.1 × 10 ⁻² ^a
Na ₂ Mo ₂ O ₇ (cys) ₂ (0.42 mmol), NaBH ₄ (1.0 mmol), T = 27 °C, charge carriers ca. 0.017 mmol	2–9 × 10 ⁻² ^b
nitrogenase, ATP, S ₂ O ₄ ²⁻ , pH 6–8	200 ^c
(SN) _x , pH 13, molybdate dipped, V = -1.46 V vs. SCE	1–10 × 10 ⁻⁴ ^d

^a Reference 8c. ^b Reference 13. ^c Reference 4. ^d Based on coverage level on order of 10⁻¹¹ mol/cm².

presence of iron in this case does not enhance the reaction. It is interesting to note that all molybdenum(VI) treated electrodes, with one exception, produced only trace amounts of C₂H₆ on C₂H₂ reduction. This one electrode produced C₂H₄ and C₂H₆ at about the same rate.²⁸ It appears that if some form of immobilized molybdenum species is capable of producing C₂H₆, this form is not normally present to an appreciable extent. It is interesting to compare the relative rates of acetylene conversion at the molybdenum-treated (SN)_x electrodes with both the other electrochemical systems^{9,12} and the enzyme nitrogenase. In order to compare the rates of electrochemical conversion found in these studies to those of Schultz,⁹ it is necessary to take into account the relative electrode surface areas. Schultz reports data for conversion at a 12 cm² Hg pool in a millimolar solution of Na₂Mo₂O₇S₂(cys)₂ which had been saturated with acetylene. The rates are of the order of 0.1–0.07 μmol of ethylene produced per min, or about 0.008–0.06 μmol per min per cm² of electrode area. Rates found for (SN)_x electrodes at the conditions considered optimal in terms of electrode stability vs. conversion rate (-1.46 V vs. SCE, pH 13, molybdate-dipped (SN)_x electrode) ranged from 0.2 to 20 nmol per min. This wide range results not only from the wide range in physical surface area and metal-binding ability^{3d} but from the range in relative electrochemical area, which can be measured by the current response in 50 mM Fe(CN)₆⁻ during electrode checks.²⁹ The rates mentioned above for (SN)_x normalized for electrochemical surface area than become 1–10 μmol per min per cm². In the upper range, this is approximately 500 times the net rate observed by Schultz and co-workers.³⁰ Electrode areas were not given for Tanaka's system,¹² but unless the electrode areas are very small, the rate in micromoles of C₂H₄ per minute per square centimeter is much slower than that for the modified (SN)_x.

In order to compare the above rates to those found by the groups involved in chemical conversion of acetylene, the net rates given here are calculated on a rate per mole of molybdenum. The results are tabulated in Table II. This comparison indicates that the rates of conversion at molybdate-dipped (SN)_x under the conditions described are about 10⁷ times the rates achieved in the chemical systems, and approximately 10³ times that of the enzyme. As the pH dependency and lack of concomitant hydrogen evolution indicate the mechanism of C₂H₂ reduction at molybdenum-immobilized (SN)_x electrodes is not the same as that for the nitrogenase-catalyzed reduction, it is not, however, possible to infer

(23) A. Seidell, "Solubilities of Organic Compounds", Van Nostrand, New York, 1941, pp 74 and 95.

(24) T. E. Weichselbaum, J. C. Hagerty, and H. B. Mark, Jr., *Anal. Chem.*, **41**, 848 (1969).

(25) J. E. Hugheey, "Inorganic Chemistry", Harper and Row, New York, 1978, p 186.

(26) M. E. Peover, In "Electroanalytical Chemistry", A. J. Bard, Ed., Marcel Dekker, New York, 1967.

(27) An electrode was dipped as described for the molybdate experiments in 1 M Fe(NO₃)₃ in 0.05 M HNO₃. At -1.46 V vs. SCE, 0.3 μmol had been produced after 8.5 h.

(28) Only this one instance occurred in which a ratio of greater than 1:10 ethane:ethene was produced, with most trials producing considerably less. The origin of this anomaly is not known; however, the currents observed were about 10 times the usual values.

(29) R. J. Nowak, Ph.D. Dissertation, 1977.

(30) One must keep in mind that a net rate is given here. The reduction process occurring at the molybdate-treated (SN)_x electrode is undoubtedly heterogeneous while the process using a mercury pool electrode could be either heterogeneous or homogeneous (the molybdenum complex could be acting as a mediator for carrying the electrons to solution phase C₂H₂ or as an "electron bridge"). The true mechanism in the mercury pool electrode case is not clear.

from our studies that these systems would show similar activity for the reduction of nitrogen.

Acknowledgment. This research was supported by the National Science Foundation under Grant No. CHE76-04321. Additional support was received by J.F.R. from the University Research

Council of the University of Cincinnati. We also wish to thank Dr. Gail Ingerholm of the Procter and Gamble Co. for performing the ESCA experiments and Mr. Alfred Kornel for the mass spectral analyses.

Registry No. Acetylene, 74-86-2; (SN)_x, 56422-03-8; Mo, 7439-98-7.

Reactions of Al⁺ and Mg⁺ with Alcohols and Organic Halides in the Gas Phase

Jack S. Uppal and Ralph H. Staley*¹

Contribution from the Department of Chemistry, Massachusetts Institute of Technology, Cambridge, Massachusetts 02139. Received May 6, 1981

Abstract: The chemistry of Al⁺ and Mg⁺ with alkyl halides and alcohols is studied by ion cyclotron resonance spectroscopy. Alkyl chlorides react with Al⁺ and Mg⁺ by chloride transfer when this is exothermic. In addition, Mg⁺ induces the dehydrochlorination of alkyl chlorides to produce Mg⁺-alkene complexes. Displacement of the alkene by the alkyl chloride is followed by a second elimination-displacement sequence resulting in Mg(RCl)₂⁺. Both Al⁺ and Mg⁺ induce the dehydration of alcohols to give Al(H₂O)⁺ and Mg(H₂O)⁺. Ligand displacement reactions result in Al(ligand)⁺ and Mg(ligand)₂⁺ as the final product species. In the presence of strong proton bases, proton transfer from the M(H₂O)⁺ intermediates is also observed, establishing upper limits on the metal hydroxide proton affinities, PA(MOH) ≡ D(MOH-H⁺); PA(AlOH) ≤ 220.4 kcal/mol and PA(MgOH) ≤ 224.3 kcal/mol.

Relative gas-phase binding energies of organic molecules, L, to metal cation species, M⁺, have recently been determined by measuring the equilibrium constant for ligand exchange, reaction 1, using ion cyclotron resonance (ICR) techniques. The results

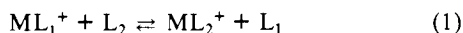

of a series of measurements can be combined to establish a scale of ligand binding energies, *D*(M⁺-L). Lithium cation, Li⁺, generated by a thermoionic source has been studied utilizing the dehydrohalogenation reactions 2 and 3 with alkyl halides to

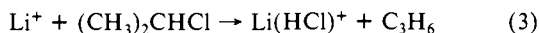
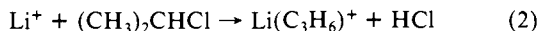

produce the initial metal-ligand species.^{2,3} Electron-impact ionization of CpNi(NO) (Cp ≡ η⁵-C₅H₅, cyclopentadienyl radical) has been used to study ligands bound to CpNi⁺ where the parent ion CpNi(NO)⁺ is utilized directly as the initial metal-ligand species.^{4,5} Data sets for Li⁺ and CpNi⁺ with over 30 ligands were obtained in these studies. Comparison of these results with each other and with the existing data set for proton affinities PA(B) ≡ *D*(B-H⁺) has provided useful quantitative insight into the interaction of metal ion species with organic molecules.

Attempts to utilize other volatile organometallics as precursors for studies of ligand binding energies have been less successful. Qualitative ordering of relative ligand binding energies was established for TiCl₃⁺, CpCo(CO)⁺, and CpCo⁺ utilizing the parent ions of TiCl₄ and CpCo(CO)₂ and the fragment ion CpCo(CO)⁺ from CpCo(CO)₂ as the initial metal-ligand species, respectively.^{6,7} Extensive quantitative results were *not* obtained in these systems.

With TiCl₄, reactions of the neutral TiCl₄ with organic molecules severely limited the set of molecules which could be studied.⁶ With CpCo(CO)₂, condensation with CpCo(CO)₂ to give cluster species containing two or more cobalt atoms consumed the CpCo(L)⁺ and CpCo(CO)(L)⁺ species before the ligand-exchange reactions could approach equilibrium.⁷ This problem was also noted with CpNi(NO) but was less severe.^{4,5}

The thermionic source used to generate Li⁺ is limited to alkali and other metals with low ionization potentials. However, a universal source of atomic metal cations for ICR studies has recently been developed.⁸⁻¹¹ This employs a pulsed YAG laser to volatilize/ionize metal targets inside the ICR cell. B, C, Mg, Al, Ti, V, Cr, Mn, Fe, Co, Ni, Cu, Zn, Zr, Nb, Rh, and Ag cations have been generated and studied in our laboratory with this source. Results of studies of reactions of Cu⁺ and Ti⁺ with organic halides have been reported.^{9,10}

A requirement for use of atomic metal cations as ionic precursors in ligand binding energy studies is that a reaction suitable for the generation of initial metal-ligand species be available. Direct condensation of ligands with the metal cation has been observed for strongly bound ligands.^{2,3,10,11} This is not suitable for ligand binding energy studies because it is usually too slow at the low pressures needed to trap the ions for times long enough for the ligand exchange reaction to approach equilibrium. Also, it is not effective with weakly bound molecules. The preferred reaction should be fast at low pressures and result in a product with a relatively low binding energy. Since the initial product will be readily displaced by the precursor neutral if the precursor is a stronger ligand, the precursor neutral should also be a weak ligand. Suitable precursor molecules and reactions to give the initial metal-ligand species may vary considerably from one metal cation to another.

The present paper reports studies of the chemistry of Mg and Al cations with alcohols and organic halides. Aspects of the

(1) Address correspondence to this author at Central Research Department, Experimental Station, DuPont Co. E356, Wilmington, Del. 19898.

(2) Staley, R. H.; Beauchamp, J. L. *J. Am. Chem. Soc.* **1975**, *97*, 5920-5921.

(3) Woodin, R. L.; Beauchamp, J. L. *J. Am. Chem. Soc.* **1978**, *100*, 501-508.

(4) Corderman, R. R.; Beauchamp, J. L. *J. Am. Chem. Soc.* **1976**, *98*, 3998-4000.

(5) Corderman, R. R.; Beauchamp, J. L., submitted for publication.

(6) Uppal, J. S.; Johnson, D. E.; Staley, R. H. *J. Am. Chem. Soc.* **1981**, *103*, 508-511.

(7) Jones, R. W.; Staley, R. H. *Int. J. Mass Spectrom. Ion Phys.* **1981**, *39*, 35-45.

(8) Cody, R. B.; Burnier, R. C.; Reents, W. D., Jr.; Carlin, T. J.; McCrery, D. A.; Lengel, R. K.; Freiser, B. S. *Int. J. Mass Spectrom. Ion Phys.* **1980**, *33*, 37-43.

(9) Burnier, R. C.; Carlin, T. J.; Reents, W. D., Jr.; Cody, R. B.; Lengel, R. K.; Freiser, B. S. *J. Am. Chem. Soc.* **1979**, *101*, 7127-7129.

(10) Jones, R. W.; Staley, R. H. *J. Am. Chem. Soc.* **1980**, *102*, 3794-3798.

(11) Uppal, J. S.; Staley, R. H. *J. Am. Chem. Soc.* **1980**, *102*, 4144-4149.